

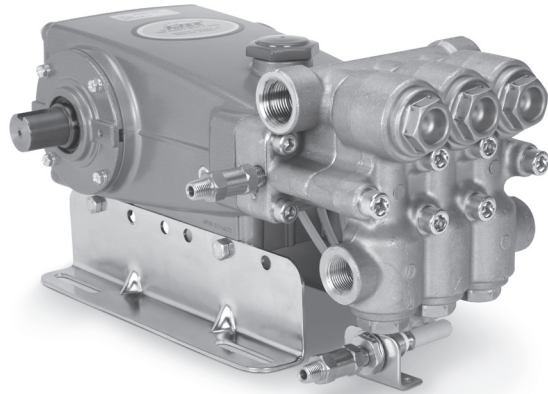

# PIJTTERSEN

E-mail : [info@pijtersen.nl](mailto:info@pijtersen.nl) / [info@catpumps.nl](mailto:info@catpumps.nl)  
Internet: [www.pijtersen.nl](http://www.pijtersen.nl) / [www.catpumps.nl](http://www.catpumps.nl)



## 15 Frame Plunger Pump

**Brass Flushed Model**

# 1530RSCM.C02

### FEATURES

- Triplex design delivers high efficiency and low pulsation.
- Durable dual V-Packings are lubricated and cooled by pumped liquid.
- Pre-set Lo-Pressure seals provide secondary protection against external leaks and require no packing adjustment.
- Special high-density, polished, concentric plungers provide a true wear surface and extended seal life.
- Special formulated seals and V-Packings offer unmatched performance and extended life.
- Wet-end easily serviced without entering crankcase.

### SPECIFICATIONS

	U.S. Measure	Metric Measure
Flow .....	5.0 gpm	(19 lpm)
Pressure Range.....	400 to 1800 psi	(28 to 124 bar)
RPM .....	450 rpm	(450 rpm)
Inlet Pressure Range.....	300 to 800 psi	(21 to 55 bar)
<b>Note:</b> Temperature and pressure must be maintained to keep incoming C02 in a liquid state.		
Bore .....	0.984"	(25 mm)
Stroke.....	1.181"	(30 mm)
Crankcase Capacity.....	42 oz.	(1.26 l)
Maximum Liquid Temperature .....	140°F	(60°C)
Inlet Ports (2) .....	1" NPTF	(1" NPTF)
Discharge Ports (2).....	3/4" NPTF	(3/4" NPTF)
Pulley Mounting .....	Either Side	(Either Side)
Shaft Diameter .....	1.181"	(30 mm)
Weight.....	55 lbs.	(25 kg)
Dimensions.....	17.26 x 11.18 x 7.4"	(438 x 284 x 188 mm)

### ⚠ CAUTIONS AND WARNINGS

All High Pressure Systems require a primary pressure regulating device (i.e. regulator, unloader) and a secondary pressure relief device (i.e. pop-off valve, relief valve). Failure to install such relief devices could result in personal injury or damage to pump or property. CAT PUMPS does not assume any liability or responsibility for the operation of a customer's high pressure system.

Read all CAUTIONS and WARNINGS before commencing service or operation of any high pressure system. The CAUTIONS and WARNINGS are included in each service manual and with each Accessory Data sheet. CAUTIONS and WARNINGS can also be viewed online at [www.catpumps.com/cautions-warnings](http://www.catpumps.com/cautions-warnings) or can be requested directly from CAT PUMPS.

### WARRANTY

View the Limited Warranty on-line at [www.catpumps.com/warranty](http://www.catpumps.com/warranty).

### ELECTRIC HORSEPOWER REQUIREMENTS

FLOW		PRESSURE			RPM
		psi 1200	psi 1500	psi 1800	
U.S. gpm	lpm	bar	bar	bar	450
5.0	19	85	105	124	
		4.1	5.1	6.2	

<b>DETERMINING THE PUMP R.P.M.</b>	$\frac{\text{Rated gpm}}{\text{Rated rpm}}$	=	$\frac{\text{"Desired" gpm}}{\text{"Desired" rpm}}$
<b>DETERMINING THE REQUIRED H.P.</b>	$\frac{\text{gpm x psi}}{1460}$	=	Electric Brake H. P. Required
<b>DETERMINING MOTOR PULLEY SIZE</b>	$\frac{\text{Motor Pulley O.D.}}{\text{Pump rpm}}$	=	$\frac{\text{Pump Pulley O.D.}}{\text{Motor rpm}}$

See complete Drive Packages [Incls: Pulleys, Belts, Hubs, Key] Tech Bulletin 003.  
Refer to pump **Service Manual** for repair procedure and additional technical information.

# PARTS LIST

ITEM	PART NUMBER	DESCRIPTION	QTY
	<b>1530RSCM.C02</b>	<b>MATL</b>	
2	990036	STL Key (M8x7x40) (Use With Hub 990012)	1
	30067	STL Key (M8x7.5x25) (Use With Hub 30059)	1
5	125824	STCP R Screw, Sems HHC (M6x16)	8
8	43496	AL Cover, Bearing	2
10	11340	NBR O-Ring, Bearing Cover - 70D	2
11	43495	NBR Seal, Oil, Crankshaft - 70D	1
12	815281	FBR Shim, Split 2 pc	0-6
13	814800	S Shim, Split 2 pc	0-4
15	39060	STL Bearing, Roller	2
20	768600	TNM Rod, Connecting Assembly (w/PLM Bushing)	3
25	43494CS	FCM Crankshaft, Single End	1
30	990280	AL Cover, Insert Bearing	1
31	828710	— Protector, Oil Cap w/Foam Gasket	1
32	43211	ABS Cap, Oil Filler	1
33	14177	NBR O-Ring, Filler Cap - 70D	1
37	92241	— Gauge, Oil, Bubble w/Gasket - 80D	2
38	44428	NBR Gasket, Flat, Oil Gauge - 80D	2
40	126541	STCP R Screw, Sems HHC (M6x20)	4
48	25625	STCP Plug, Drain (1/4"x19BSP)	1
49	23170	NBR O-Ring, Drain Plug - 70D	1
50	43491	AL Cover, Rear	1
51	44834	NBR O-Ring, Rear Cover - 70D	1
53	115471	AL Crankcase w/Guide Pins	1
64	763507	CM Pin, Crosshead (w/Flats)	3
65	76228	SHS Rod, Plunger (w/Set Screws)	3
69	126592	STCP R Washer, Oil Seal	3
70	43500	NBR Seal, Oil Crankcase - 80D	3
75	43506	S Slinger, Barrier	3
90	48606	CC Plunger, Ceramic (M25x92)	3
96	43235	PTFE Back-up-Ring, Plunger Retainer	3
97	17399	NBR O-Ring, Plunger Retainer - 80D	3
98	45891	CU Gasket, Plunger Retainer	3
99	104360	S Retainer, Plunger	3
100	769509	AL Retainer, Seal	3
101	999490	D Adapter	3
102	999492	NY Tubing	3
103	999491	PLM Manifold	1
104	22177	BBCP Plug (1/4" NPTM)	1
105	33937	SS Valve, Check (1/4" NPTM)	2
106	701944	SFTA Seal, LPS w/SS-Spg	3
110	48608C	FBB Manifold, Inlet (Flushed)	1
112	14200	NBR O-Ring, Inlet Manifold - 70D	3
113	34338	BB Union (1/4" NPTM)	1
114	34347	STZP Bracket	1
115	990776	STZP R Screw, HHC (1/4"-20x1/2")	2
117	126515	STCP R Screw, HSH (M10x55)	4
126	48538	BB Adapter, Female	3
127	44610	STG* V-Packing	6
128	48539	BB Adapter, Male	3
142	48550	BB Spacer w/Coil Springs	3
155	17629	NBR O-Ring, Spacer - 80D	6
156	28243	PTFE Back-up-Ring, Spacer	6
162	48363	D Back-up-Ring, Seat	6
163	26142	NBR O-Ring, Seat - 80D	6
164	48596	S Seat, Q.V. Stepped	6
166	48686	SS Valve, Q.V.	6
167	48687	SS Spring, Valve [12/02]	6
168	44735	PVDF Retainer, Spring	6
170	44794	SS Washer, Spring Retainer	6
171	48689	SS Spring, Coil [12/02]	6
172	17629	NBR O-Ring, Valve Plug - 80D	6
174	48597	FBB Plug, Valve	6
185	48610	FBB Manifold, Discharge	1
188	126519	STCP R Screw, HSH (M12x70)	6
260	30613	STZP Rail, Angle Assy	1

# EXPLODED VIEW

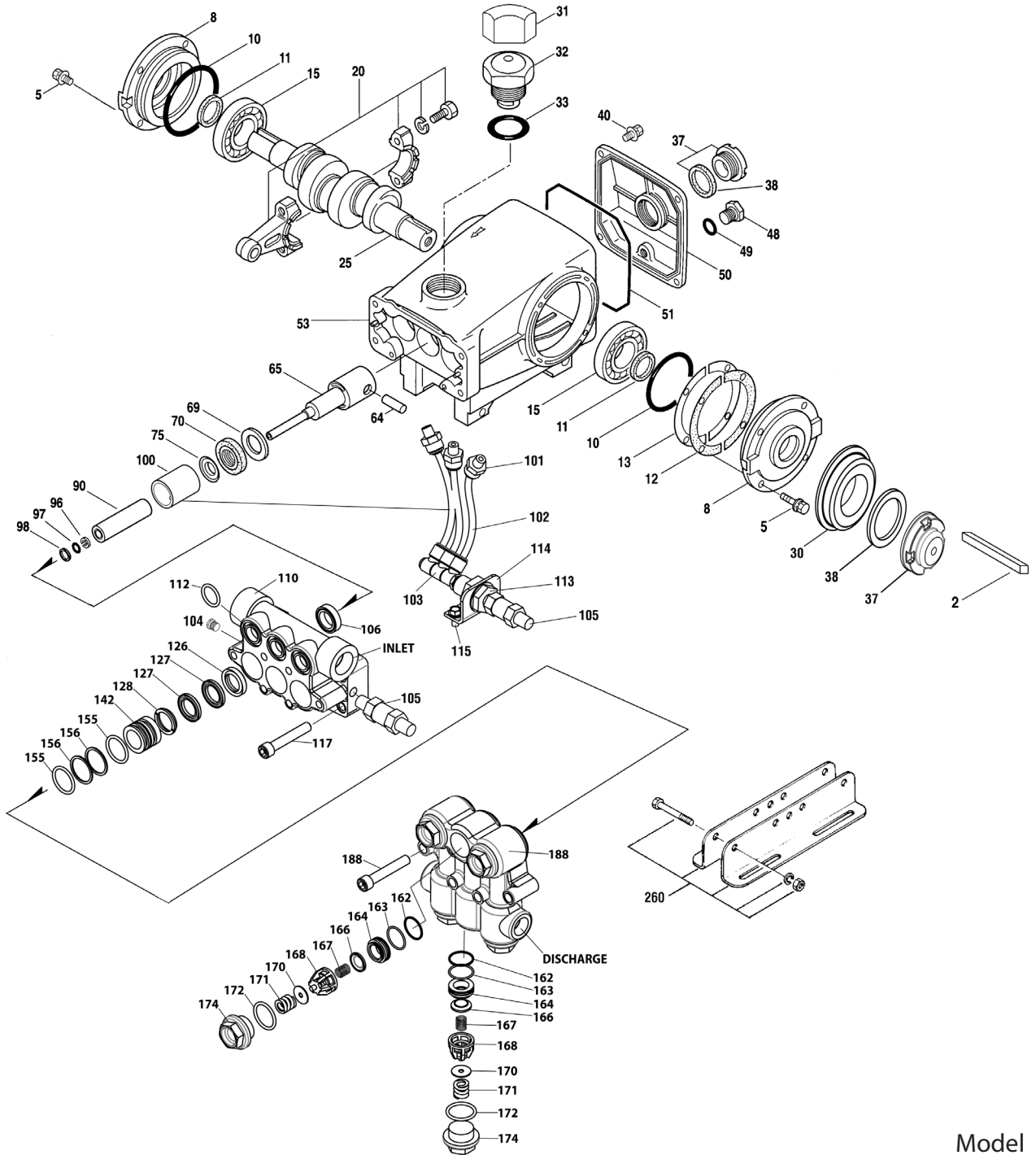

Model  
1530RSCM.C02  
April 2014

## 1530RSCM.C02 MATL

270	30059	STL	Hub, "H", M30 (Keyway M8) (Use Wth Key 30067)	1
	990012	STL	Hub, "B", M30 (Keyway M8) (Use Wth Key 990036)	1
300	31355.C02	NBR	Kit, Seal (Incls: 97,106,112,127,155,156)	1
310	31360	NBR	Kit, Valve (Incls: 162,163,164,166,167,168,170,172)	2
—	6100	—	Oil, Case (12 Bottles) ISO 68 Hydraulic (Fill to specified crankcase capacity prior to start-up)	1

*Italics are optional items. [ ] Date of latest production change.*

R Components comply with RoHS Directive. \* Review material codes for individual items (STG generally may be used as alternate). See Tech Bulletins 002, 003, 024, 035, 036, 043, 053, 074, 077, 083, and 085 for additional information.

MATERIAL CODES (Not Part of Part Number): ABS=ABS Plastic AL=Aluminum BB=Brass BBCP=Brass Chrome Plated  
CC=Ceramic CM=Chrome-moly CU=Copper D=Acetal FBB=Forged Brass FBR=Fiber FCM=Forged Chrome-moly NBR=Medium Nitrile (Buna-N) NY=Nylon  
PLM=Unspecified Poly PTFE=Pure Polytetrafluoroethylene PVDF=Polyvinylidene Fluoride S=304SS SFTA=Special Blend PTFE (Tan)  
SHS=304SS/High Strength SS=316SS STCP=Steel/Chrome Plated STG=Special Blend PTFE White STL=Steel  
STZP=Steel/Zinc Plated TNM=Special High Strength

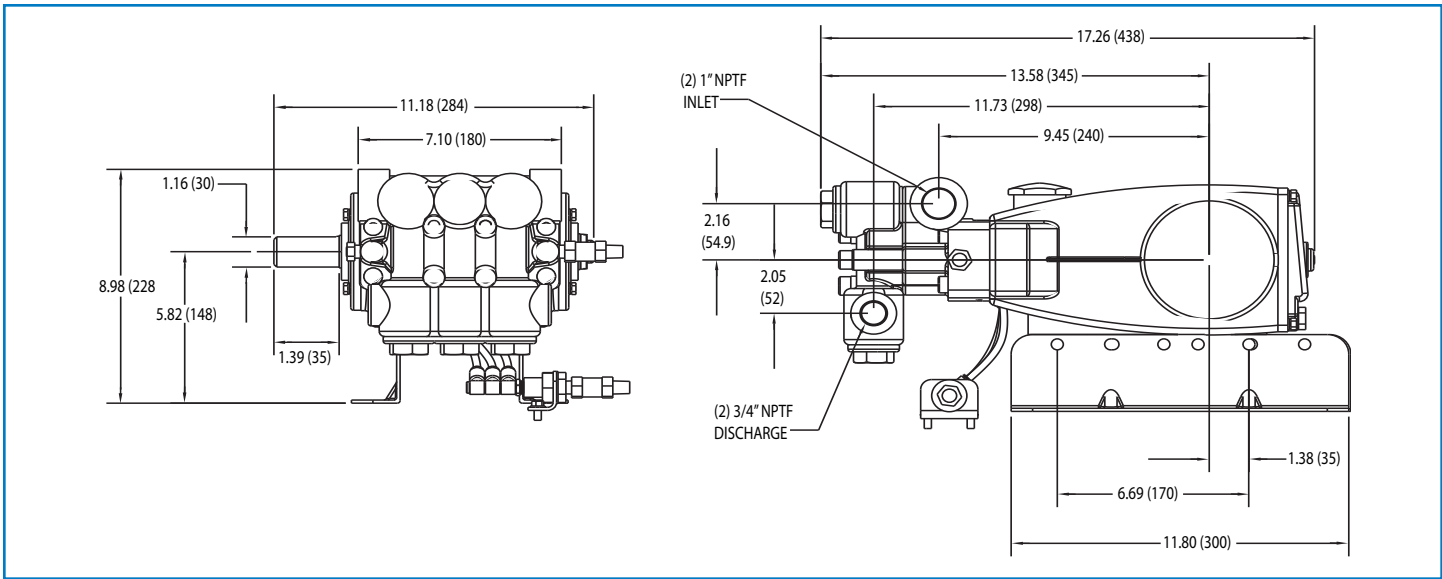

Models 1530RSCM.C02



# PIJTTERSEN



*The Pumps with Nine Lives*

Pijttersen B.V.  
 Beneluxweg 33  
 9636 HV Zuidbroek  
 Tel.: +31(0)50-8200963

KvK 01013855  
 BIC RABONL2U  
 BTW NL002166811B01  
 IBAN NL24 RABO 0353 2970 97

[www.pijttersen.nl](http://www.pijttersen.nl) - [info@pijttersen.nl](mailto:info@pijttersen.nl) | [www.catpumps.nl](http://www.catpumps.nl) - [info@catpumps.nl](mailto:info@catpumps.nl)